



GUIDANCE ON THE MEANING OF BENEFICIAL OWNER

Contents

Introduction	2
Control through ownership – Tier 1.....	4
FAQ 1: What is control through ownership?	4
FAQ 2: What is meant by holding shares or rights directly?.....	5
FAQ 3: What is meant by holding shares or voting rights indirectly?	7
FAQ 4: What is meant by holding the right to appoint or remove directors or officials indirectly?	10
FAQ 5: What happens when a trust holds shares or rights in a legal person?	12
FAQ 6: What is the significance of corporate beneficial owners in Regulation 1(3)?	16
FAQ 7: How do nominee arrangements fit into the registration framework?	18
Control through other means – Tier 2	19
FAQ 8: When does a resident agent have to look at ultimate control through other means i.e. Tier 2?.....	19
FAQ 9: What is meant by ultimate control through other means?	19
Control by official position – Tier 3.....	244
FAQ 10: Who is a senior managing official for the purposes of Regulation 1(c)?	244

Introduction

This guidance is issued by the Registrar of Beneficial Ownership of Legal Persons in the exercise of his powers under section 29 of the Beneficial Ownership of Legal Persons (Alderney) Law, 2017 (the Law). It provides further information on the definition of beneficial ownership as set out in the Beneficial Ownership (Alderney) (Definition) Regulations, 2017 (the Regulations).

The guidance follows the order of the 3-tiered approach to the definition of beneficial owner in the Regulations, which in turn mirrors that in the FATF standards. The starting point is always whether any person within Tier 1 (a natural person with control through ownership) exists or can be identified. If that is the case, that person (or persons) must be treated as the beneficial owner. If no person within Tier 1 exists or can be identified, or if a person within Tier 1 has been identified but there is reason to believe that another natural person is also ultimately exercising control over the company by other means, Tier 2 must be looked at. In the second situation, both the person within Tier 1 and any person within Tier 2 are the beneficial owners. If there is nobody within Tiers 1 and 2, a natural person within Tier 3 (senior managing official) will be the beneficial owner.

The guidance takes the form of FAQs, which are supplemented by some examples of control through ownership. The focus of the guidance is on companies with non-straightforward ownership structures, but it is recognised that, in practice, ownership of most Alderney companies does not involve structures and relationships as complex as those in some of the examples, which have been used for illustration purposes only¹.

The guidance is intended to assist in meeting the obligations under the Law and the beneficial ownership obligations under the Companies (Alderney) Law, 1994 (the Companies Law). To comply with these obligations, the principles set out in the guidance should be applied by resident agents or other interested parties to the circumstances of an individual legal person. This will involve an examination of constitutional documents and any other relevant documents (e.g., shareholder agreements and trust deeds), as well as looking at chains of ownership and other circumstances such as relationships between legal persons and third parties.

Most resident agents will be familiar with this type of exercise, as it is similar to the customer due diligence obligations under the anti-money laundering/countering terrorist financing (AML/CFT) framework, which apply to all resident agents except non-regulated locally resident individual directors acting on a purely voluntary basis. It is however important to be aware that the obligations under the Law and the Companies Law apply to all resident agents, irrespective of whether they are regulated parties or otherwise subject to the AML/CFT framework.

¹ In all of the examples, natural persons are denoted by a capital letter on its own and beneficial owners are highlighted in red.

The guidance is not intended to replace the Regulations and it does not cover all matters addressed in the Regulations. It is therefore important that both are read together to have a proper understanding of the definition of beneficial owner under the Law.

Control through ownership – Tier 1

FAQ 1: What is control through ownership?

Regulation 1(1)(a) provides that a beneficial owner is an individual who has control through ownership. Control through ownership is defined at Regulation 3 as holding more than 25% of the shares or voting rights in a company, or also holding the right to appoint or remove the majority of the directors of a company.

The starting point in most cases will be to consider whether a person's holding meets the threshold of more than 25% of shares or voting rights. When considering the extent of a person's holding, Part 2 of the Regulations must be borne in mind, particularly the following provisions:

- Regulation 4 – where shares or rights held jointly by two or more persons, each person must be treated as holding the entirety of the shares or rights.
- Regulation 5 – where shares or rights that are not held jointly are subject to an arrangement between the people who hold them that they will exercise their rights in the same way, each person who is party to the arrangement must be treated as holding the entirety of the shares or rights that are covered by the agreement; this applies to rights attached to shares or any other rights.
- Regulation 9 – shares held by a nominee on behalf of another person must be treated as belonging to that other person, not the nominee.
- Regulation 10 – where a person controls a right held by another, the person with control must be treated as holding the right. This is as well as the person who officially holds it if the latter also has control. If, however, the person who officially holds it must act entirely as directed by another, only that other person should be treated as holding the right.

It is important to note that, if an individual features within an ownership structure in more than one way, the value of each of that individual's holdings must be looked at to assess the overall holding.

It is also important to note that even if an individual's holding does not meet the threshold of more than 25% of shares or voting rights, that individual will still be a beneficial owner if he or she has the right to appoint or remove the majority company directors. For the avoidance of doubt, the above guidance applies equally to companies limited by shares, companies limited by guarantee, unlimited companies, and mixed liability companies.

Another factor to bear in mind is that there may be an individual within an ownership structure who does not meet any of the tests for control through ownership (i.e., is outside Tier 1) but who is exercising control through other means (i.e., within Tier 2), in line with the principles set out under FAQ 8.

Please note that there will be an Ordinance and guidance to address nominee relationships, which will be relevant in the situations outlined above under Regulations 9 and 10.

FAQ 2: What is meant by holding shares or rights directly?

A person holding a share or right in his or her own name holds that right directly. This may be held by the person alone or jointly with another person. Direct holdings will generally be recorded in the constitutional documents of a company such as a register of shares, but the information there will not be definitive as it is also necessary to consider whether any of the factors in Part 2 of the Regulations outlined above apply.

This is illustrated in the following examples.

Figure 1

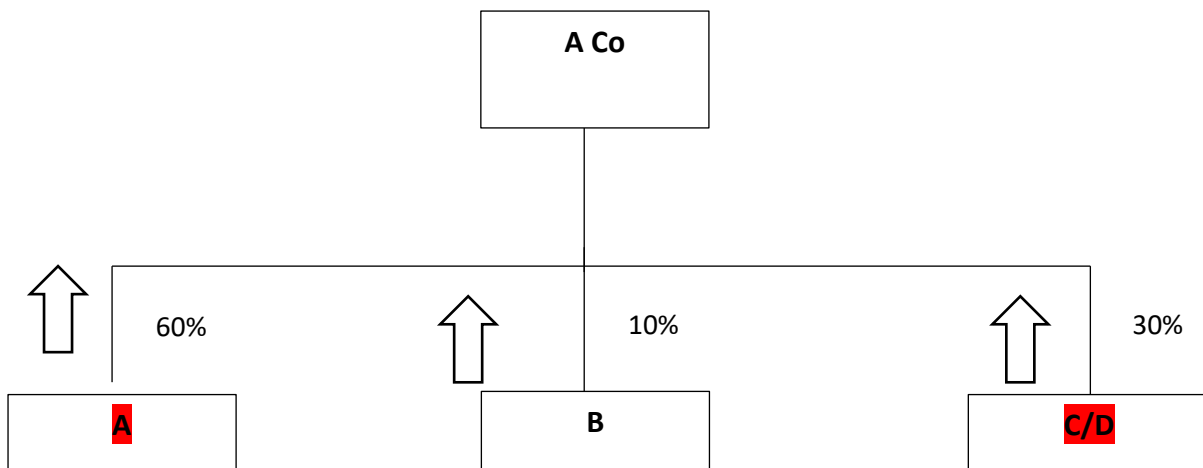

In Figure 1, A Co is an Alderney company in which A holds 60% of the shares, B holds 10% of the shares and C and D jointly hold 30% of the shares. As A holds more than 25% of the shares in G Co, A is a beneficial owner of A Co. B holds less than 25% of the shares in A Co so B is not a beneficial owner of A Co. C and D jointly hold more than 25% of the shares in A Co, and as jointly held shares are to be treated as belonging in their entirety to each person who holds them, both C and D are beneficial owners of A Co.

Figure 2

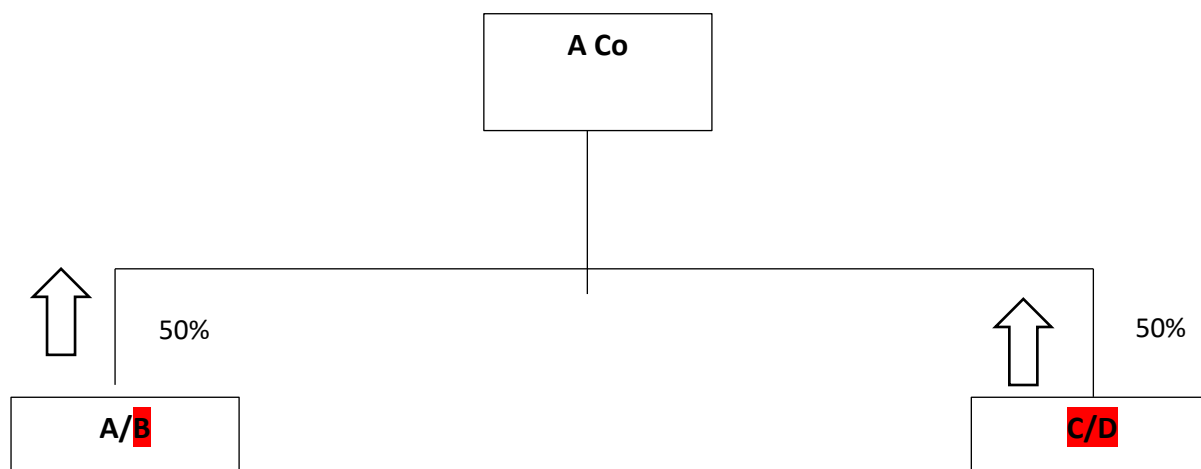

In Figure 2, A Co is an Alderney company in which A and C each hold 50% of the voting rights so each has a holding of more than 25%. Both have made agreements with third parties about the way in which their voting rights are exercised. Under an agreement which A has made with B, A must exercise those rights in the way that B directs. This means that B, not A, controls the rights held by A so for registration purposes B must be treated as holding the right, not A, and therefore B is a beneficial owner of A Co. However, it is important to recognise that A will almost certainly fall within the definition of “nominee” in the Nominee Ordinance – see FAQ 7. The position is different with C and D; C is not obliged to act at D’s direction but is nevertheless bound to obtain the consent of D before exercising the rights he holds. Therefore, C and D both control the exercise of C’s rights so for registration purposes both must be treated as holding the right and therefore both are beneficial owners of A Co.

Figure 3

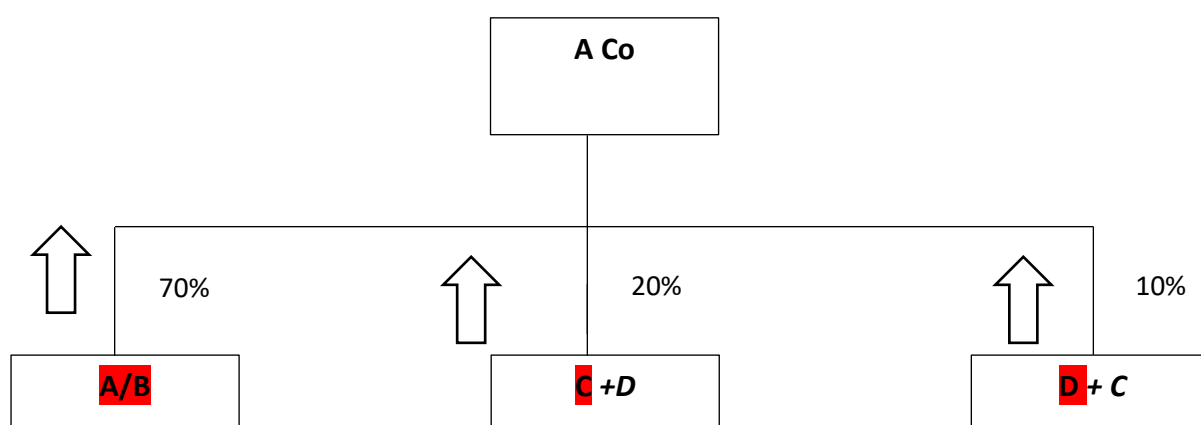

In Figure 3, A Co is an Alderney company in which A and B jointly hold 70% of the voting rights, C holds 20% of the voting rights and D holds 10% of the voting rights. As A and B must be treated as holding all their jointly owned rights for registration purposes, each holds more than 25% of the voting rights and therefore both are beneficial owners of A Co. Although neither C nor D holds more than 25% of the voting rights in A Co, they have a long- standing arrangement under which they always exercise the rights they hold in the same way. As all rights subject to the arrangement must be treated as belonging to them both for registration purposes, each is treated as holding 30% of the voting rights. C and D are therefore both beneficial owners of A Co.

Figure 4

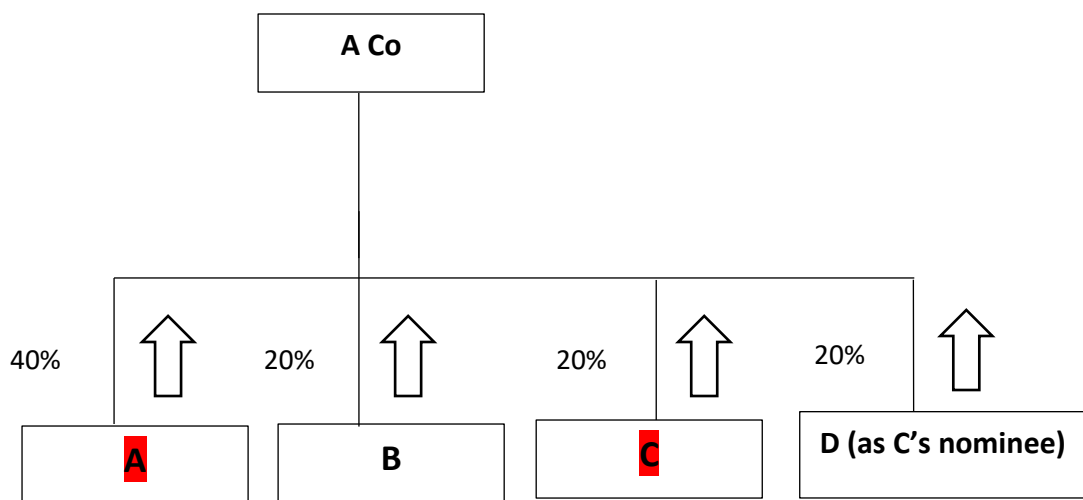

In Figure 4, A Co is an Alderney company in which A holds 40% of the shares, B and C each hold 20% of the shares and D holds 20% of the shares as nominee for C. As A holds more than 25% of the shares in A Co, A is a beneficial owner of A Co. B holds less than 25% of the shares in A Co so is not a beneficial owner of A Co. Although C only holds 20% of the shares in his own name, D holds a further 20% of the shares as C’s nominee. As shares held by one individual on behalf of another individual must be treated for registration purposes as belonging to that other individual, D’s shares must be treated as belonging to C, not D. This means that C holds more than 25% of the shares in total so C is a beneficial owner of A Co. However, it is important to recognise that D will fall within the definition of “nominee” in the Nominee Ordinance – see FAQ 7.

FAQ 3: What is meant by holding shares or voting rights indirectly?

Indirect holdings will occur where the ownership structure of the company involves one or more other entities (i.e., a chain of ownership). Resident agents must therefore look through the chain of ownership at all the different ownership interests to ensure that all natural persons (including corporate beneficial owners for these purposes) with an indirect holding

of shares or rights in the company above the 25% threshold in the Regulations are identified. The ownership interests within a chain that need to be quantified are most likely to be shares, rights or vested beneficial interests, but it is not possible to give a definitive list of the relevant ownership interests because that will depend on the features of the intervening entities, some of which may be established under the laws of other jurisdictions.

An indirect holding within an ownership chain may arise in one of two ways.

The first is when an entity holds more than 25% of the shares or rights in the company, and an individual has a majority stake (i.e., a 51% + shareholding or similar) in that entity so can control those shares or rights. The majority stake may be held directly, but it may also be held through a chain of ownership with the individual holding a majority stake in each intervening entity.

The second is where the overall value of an individual's holding in shares or rights in the company, when quantified back through the ownership chain, amounts to more than 25%. This is referred to in the examples below as the quantification test.

An individual who has indirect ownership in either or both ways is a beneficial owner of the company.

This is illustrated in the following examples.

Figure 5

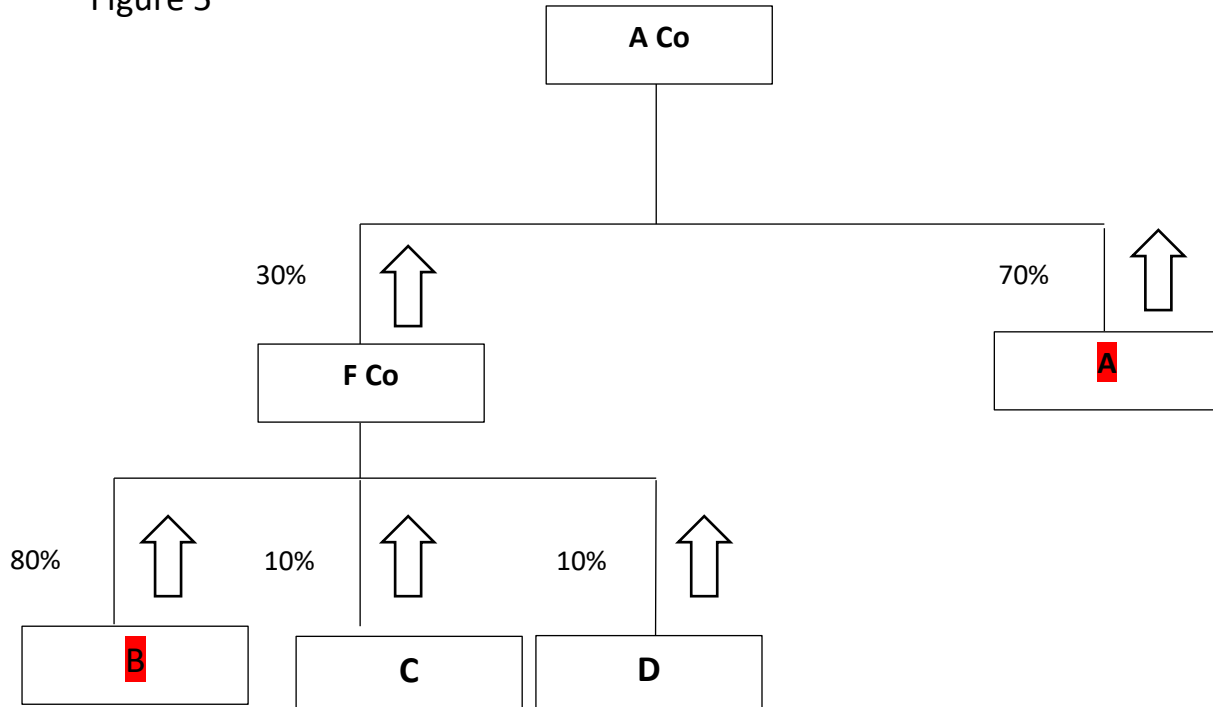

In Figure 5, A Co is an Alderney company in which 30% of the shares are held by F Co (a foreign company) and A holds the remaining 70%. Therefore, A has a direct holding of more than 25% and is a beneficial owner of A Co.

B holds 80% of the shares in F Co so has an indirect holding in A Co quantified at 24% overall (i.e., 80% of 30%). This means B does not have an overall holding in A Co of more than 25% under the quantification test, but does hold a majority stake in an entity which holds more than 25% of the voting rights in A Co. Therefore, B is a beneficial owner of A Co.

C and D each hold 10% of the shares in F Co, so each has an indirect holding in the shares in A Co of 3% overall (i.e., 10% of 30%). As they have neither an overall holding in A Co of more than 25% under the quantification test, nor a majority stake in an entity which holds more than 25% of the voting rights in A Co, they are not beneficial owners of A Co.

Figure 6

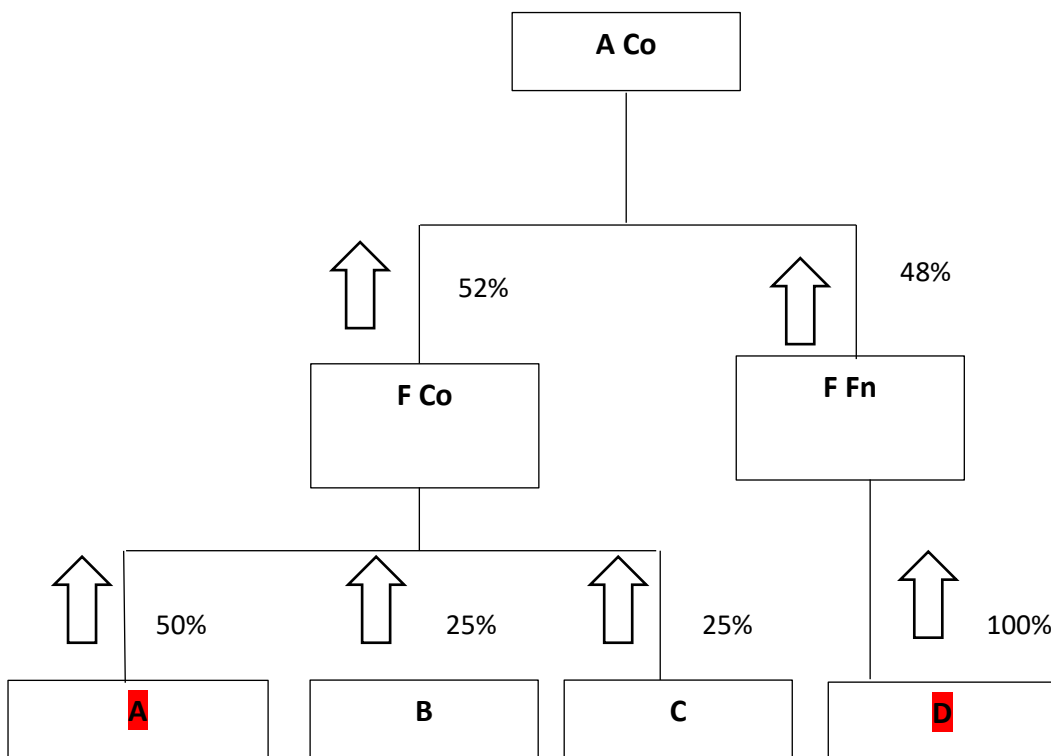

In Figure 6, A Co is an Alderney company in which 52% of the voting rights are held by F Co, a foreign company, and F Fn, a foreign foundation, holds the remaining 48%.

A holds 50% of the shares in F Co so has an indirect holding in the voting rights in A Co of 26% overall (i.e., 50% of 52%). This means A does not hold a majority stake in an entity that holds more than 25% of the voting rights in A Co but has an overall holding in the voting rights in A Co under the quantification test of more than 25%. Therefore, A is a beneficial owner of A Co.

B and C each hold 25% of the shares in F Co so both have an indirect holding in the voting rights in A Co of 13% overall (i.e., 25% of 52%). As they have neither an overall holding in the voting rights in A Co under the quantification test of more than 25% nor a majority stake in

an entity which holds more than 25% of the voting rights in A Co, they are not beneficial owners of A Co.

D has a vested beneficial interest in 100% of the assets of the F Fn so has an indirect holding in the voting rights in A Co of 48% overall (i.e., 100% of 48%). This means that D both holds a majority stake in an entity that holds more than 25% of the voting rights in A Co and has an overall holding in the voting rights in A Co under the quantification test of more than 25%. Therefore, D is a beneficial owner of A Co under both tests.

FAQ 4: What is meant by holding the right to appoint or remove directors or officials indirectly?

The definition of ownership at Regulation 3 includes holding the right directly or indirectly to appoint or remove a majority of the board of directors of a company.

Rights to appoint or remove company directors are unlikely to be quantified in a legal person's constitution or other legal documents in the same way that shareholdings or voting rights are. Therefore, the Regulations do not specify a threshold in relation to the right of appointment or removal itself. This means that any natural person who holds that right directly comes within Regulation 1(1)(a) and Regulation 3.

This is illustrated in the following example.

Figure 7

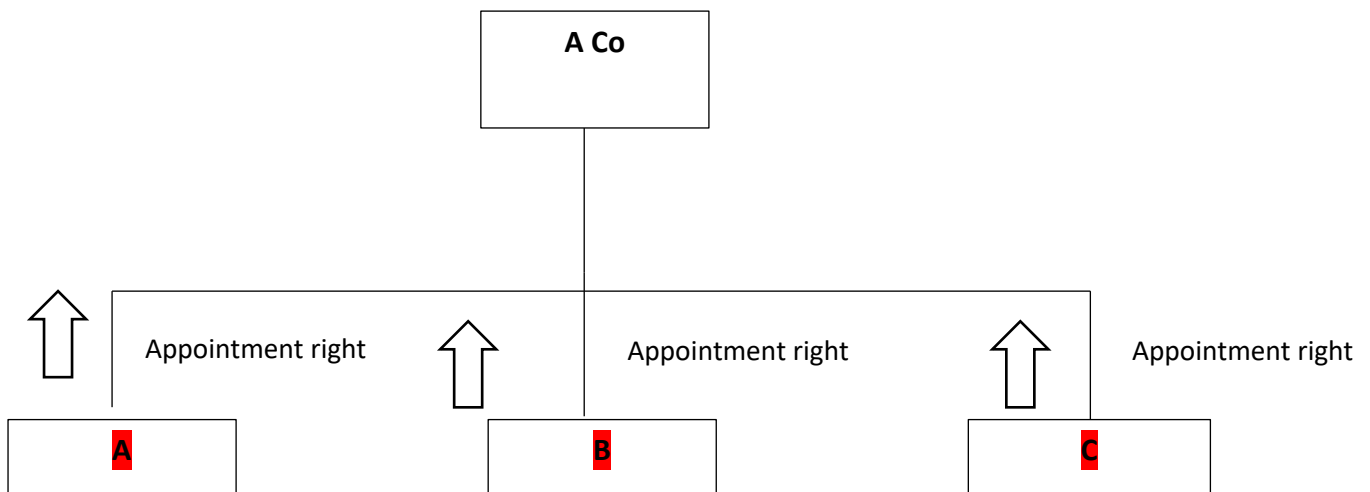

In Figure 7, A Co is an Alderney company in which A, B and C each holds the right to appoint a majority of the board of directors. All are therefore beneficial owners of A Co.

In a less straightforward case, an entity may hold the right to appoint or remove company directors. In that situation, a natural person who has a majority stake in the entity (either

directly or through a chain of ownership) will be able to control the exercise of that right so should be treated as holding the right indirectly. Therefore, resident agents should examine the holding in any entities in a chain of ownership in the same way as described above.

This is illustrated in the following examples.

Figure 8

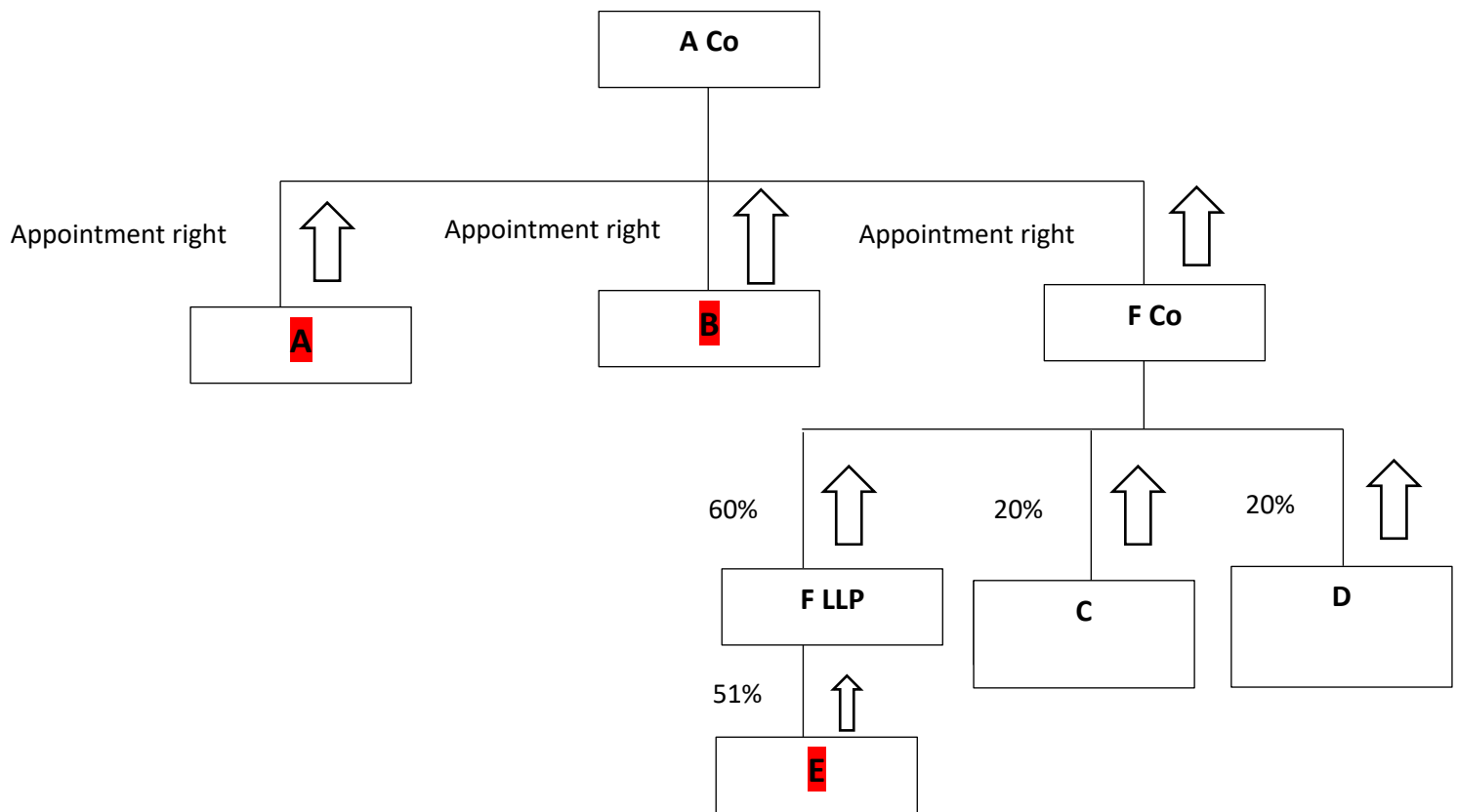

In Figure 8, A Co is an Alderney company and A, B and a foreign company, F Co, have a contractual right to appoint the majority of the company directors. This means that A and B directly hold the right of appointment and therefore both are beneficial owners of A Co.

C and D each hold 20% of the shares in F Co. As this is not a majority stake in the entity that holds the appointment right, neither C nor D is a beneficial owner of A Co.

A foreign LLP, F LLP, holds 60% of the shares in F Co. E holds 51% of the voting rights in F LLP. This means E holds a majority stake (through a chain of majority stakes) in the entity that holds the appointment right. Therefore, E holds the appointment right indirectly and is a beneficial owner of A Co.

Figure 9

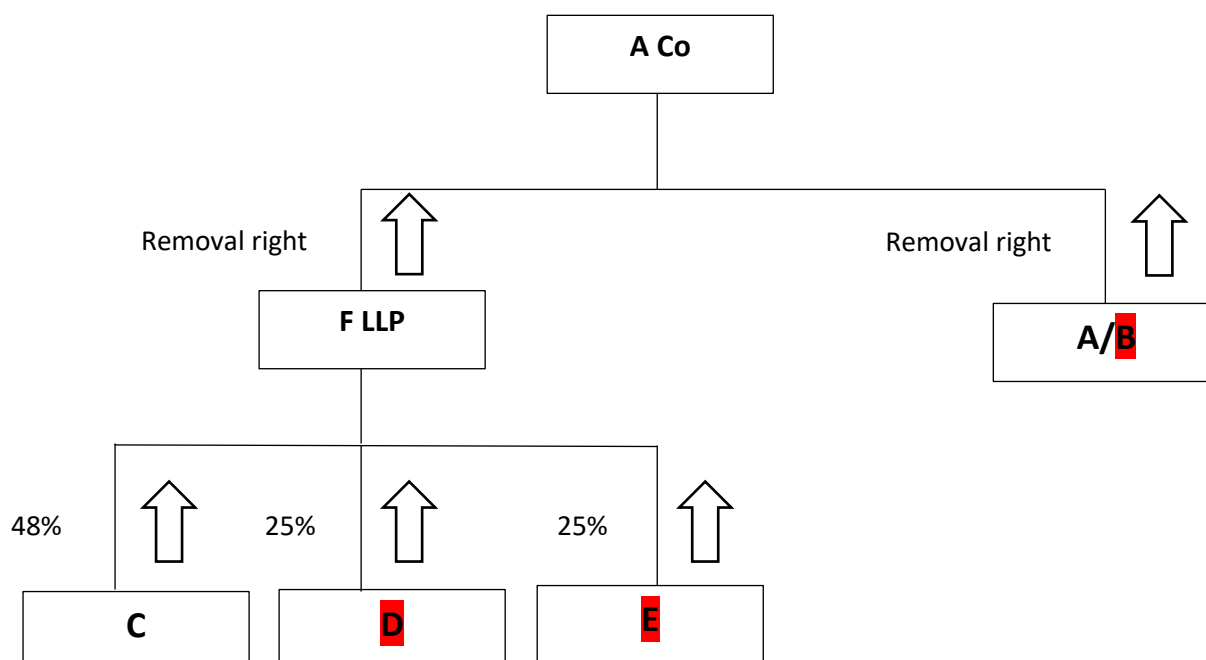

In Figure 9, A Co is an Alderney company that has entered into a written agreement giving F LLP, a foreign LLP, and A the right to remove a majority of its board of directors. A is contractually bound to exercise that right as directed by B. This means that although A holds the right of removal directly, for registration purposes B must be treated as holding it instead of A as B controls its exercise instead of A. B is therefore the beneficial owner of A Co. However, it is important to recognise that A will almost certainly fall within the definition of “nominee” in the Nominee Ordinance – see FAQ 7.

C holds 48% of the voting rights in F LLP. This means C does not hold a majority stake in an entity that holds the removal right so is not a beneficial owner of A Co. D and E each hold 26% of the voting rights in F LLP. By a longstanding arrangement D and E always exercise those rights in the same way so each must be treated as holding all the rights that are subject to the agreement. This means that each holds 52% of the rights in F LLP so each has a majority stake in an entity that holds the removal right in respect of A Co. D and E are therefore beneficial owners of A Co.

FAQ 5: What happens when a trust holds shares or rights in a legal person?

Trusts are dealt with under Regulation 2. Although trusts are by far the most likely form of legal arrangement to feature in the ownership of an Alderney company, Regulation 2 makes it clear that the provisions about persons connected to trusts apply to corresponding persons in relation to other forms of legal arrangement.

The starting point is that in any case where a trust holds more than 25% of the shares or rights in a legal person, the trustee must be treated as a beneficial owner of that legal person. If the trustee is either an Alderney corporate trustee, or a non-Alderney corporate trustee that is listed on a recognised stock exchange, only the trustee needs to be identified because in these circumstances, for the reasons given under FAQ 6 no transparency issues arise and the trustee may be treated as a corporate beneficial owner. For other corporate trustees, both the trustee itself and its beneficial owners must be identified.

In addition to the trustee, three other categories of person may be identified as the beneficial owner of the company depending on the particular circumstances of the trust.

The first category is any beneficiary of the trust if the trust is a fixed trust, i.e., one where the interest of the beneficiaries in the trust assets is certain. This does not apply to beneficiaries of discretionary trusts because their only right is to be considered for the exercise of the trustee's discretion, so they have no rights over any defined part of the trust assets. In the case of mixed trusts, i.e., those that are partly fixed and partly discretionary, only the beneficiaries of the fixed part, i.e. those whose interests are certain, need to be treated as beneficial owners.

The second category is any individual who holds one or more of the powers listed in Regulation 2(e) under the trust deed or other formal document relating to the trust. It is important to be aware that this applies only to what are sometimes described as positive or active powers, not to negative or passive powers that the individual may only use to prevent another person from acting in a particular way or which are dependent on a trigger event outside the individual's control. For example, if the trust deed specifies that a trustee is required to seek consent from a protector to a change of trustee, or the protector may remove a trustee who has been found to act improperly, that does not mean that the protector has the power to appoint or remove a trustee for the purposes of Regulation 2(e)(i).

The third category is individuals whom the resident agent of the legal person knows or believes are exercising control over the trust. It is not envisaged that this will occur with trusts where the trustee is a Bailiwick licensed fiduciary, i.e., the majority of trusts within the ownership structures of Alderney companies. This is because the fiduciary sector in the Bailiwick is fully conversant with the responsibilities of a trustee, including the long-established principle of domestic and international trust law that a trustee who permits third parties to control its actions is acting improperly. In addition, a substantial proportion of trusts within Alderney company ownership structures which do not have a regulated trustee have individuals who have previously worked in the Bailiwick's fiduciary sector as trustees. In practice therefore, the only circumstance in which it is envisaged that the third category might potentially apply is where inexperienced non-professional trustees allow themselves to be influenced by a dominant person associated with the trust (for example, the settlor).²

² In the event that it were to occur, as part of the registration process the resident agent would be required to disclose that fact to the Registrar of Beneficial Ownership, who would liaise with other authorities to explore the appropriate action to be taken against the trustee under Bailiwick law for acting in breach of his obligations.

The different situations that may arise in respect of trusts are looked at in the following examples.

Figure 10

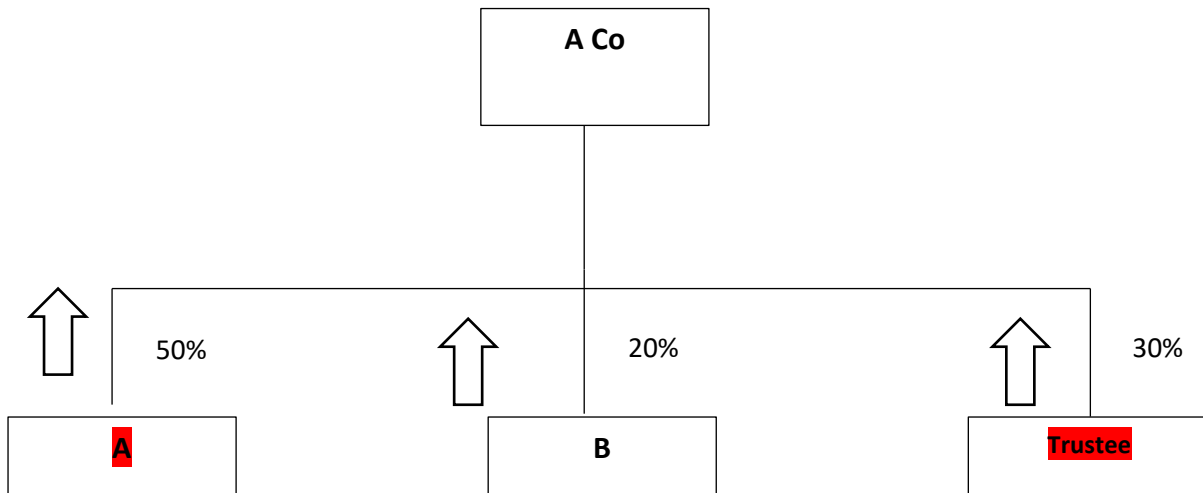

In Figure 10, A Co is an Alderney company in which A holds 50% of the shares and B holds 20% of the shares. A holds more than 25% of the shares in A Co so is a beneficial owner of A Co. B holds less than 25% of the shares in A Co so is not a beneficial owner of A Co.

A discretionary trust with an Alderney corporate trustee holds 30% of the shares. Nobody other than the trustee holds any powers in respect of the trust and the resident agent is not aware of any person exercising control over the trust other than the trustee. Therefore, the trustee is a beneficial owner of A Co.

Figure 11

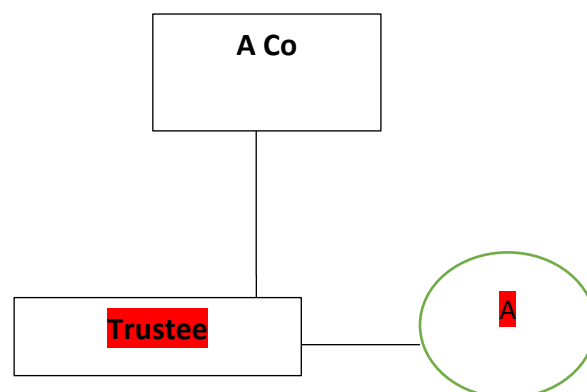

In Figure 11, A Co is an Alderney company in which all the voting rights are held by a discretionary trust with a non-Alderney corporate trustee. A is the beneficial owner of the corporate trustee. Nobody other than the trustee holds any powers in respect of the trust and the resident agent is not aware of any person exercising control over the trust other than

the trustee. Therefore, the corporate trustee and A as its beneficial owner are the beneficial owners of A Co.

Figure 12

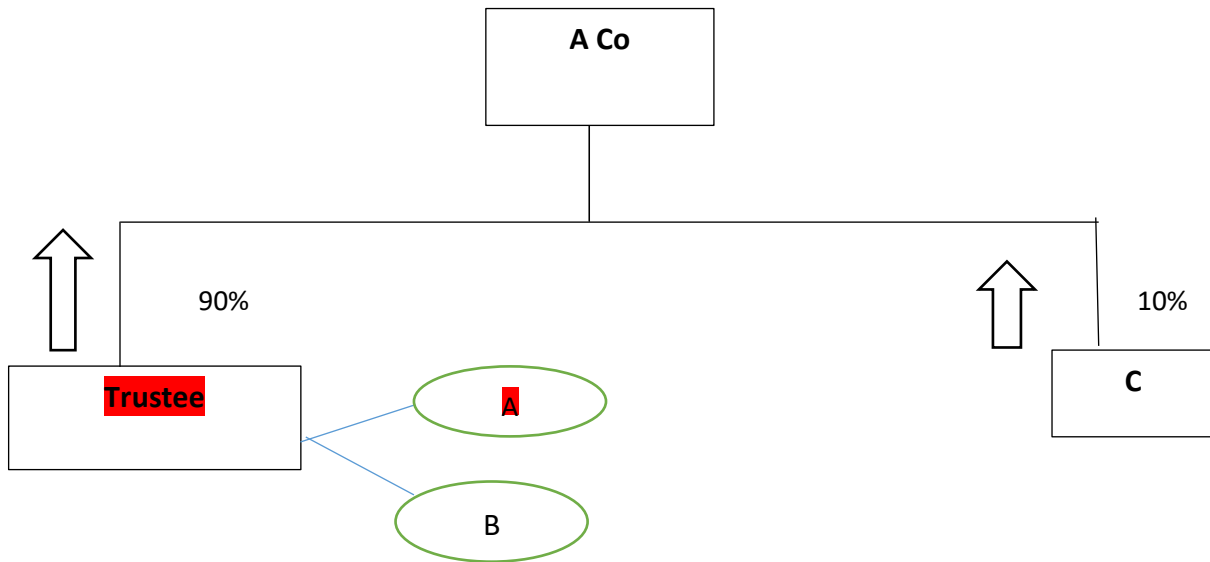

In Figure 12, A Co is an Alderney company in which 90% of the voting rights are held by a fixed trust. The trust has an Alderney corporate trustee. A is the sole beneficiary of the trust and B is a protector who, under the trust deed, has the right to be consulted over the investment decisions of the trust. Therefore, the trustee and A are beneficial owners of A Co. B is not a beneficial owner of A Co because his right to be consulted does not bring him within the Regulation 2(e) powers.

C holds the remaining 10% of the voting rights in A Co. As this is less than 25% of the voting rights, C is not a beneficial owner of A Co.

Figure 13

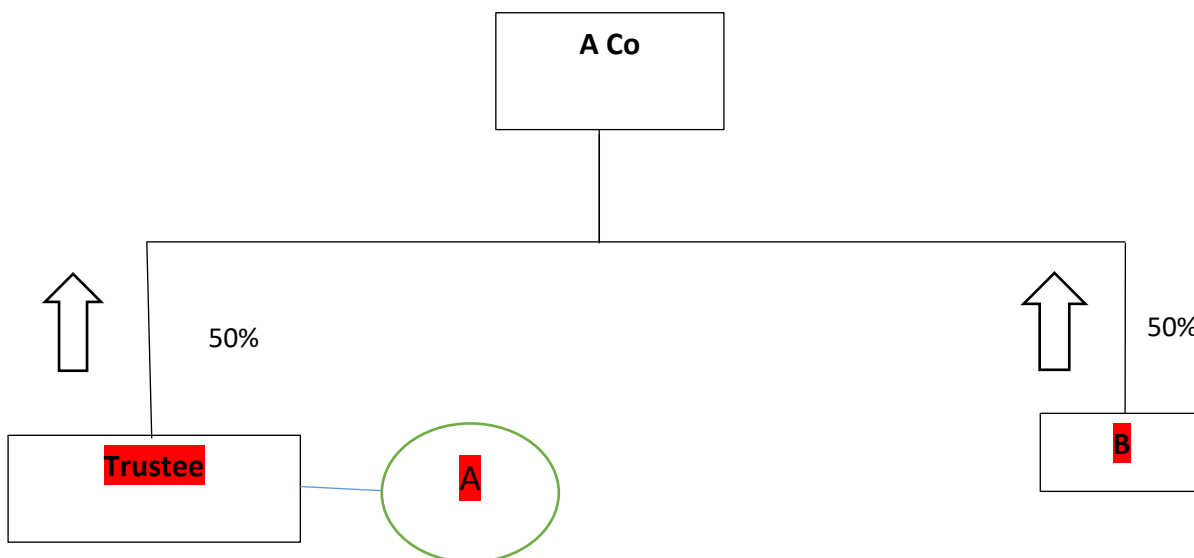

In Figure 13, A Co is an Alderney company in which 50% of the voting rights are held by a discretionary trust with an Alderney corporate trustee. Under the trust deed, A has an absolute right to amend the trust deed. As the trust holds more than 25% of the voting rights in A Co, the trustee is a beneficial owner of A Co. A is also a beneficial owner of A Co because his power to amend the trust deed brings him within the Regulation 2(e) powers. B holds the remaining 50% of the voting rights in A Co. As this is more than 25% of the voting rights, B is also a beneficial owner of A Co.

Figure 14

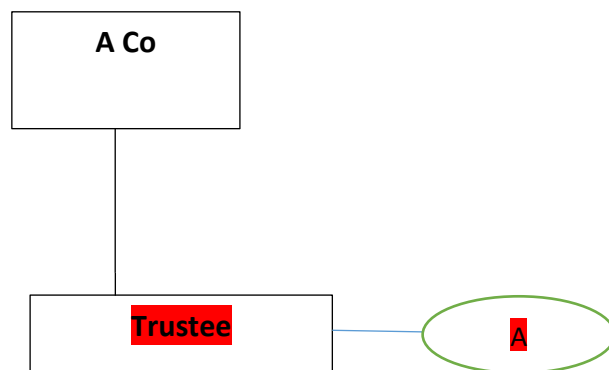

In Figure 14, A Co is an Alderney company in which all the shares are held by a discretionary trust. The resident agent of A Co is aware that the trustee is an inexperienced non-professional individual who routinely follows directions from A, the settlor, on all matters relating to the trust. Therefore, both the trustee and A must be identified as beneficial owners of A Co³.

FAQ 6: What is the significance of corporate beneficial owners in Regulation 1(3)?

The definition of beneficial owner in Regulation 1(1)(a) applies to natural persons in order to ensure that individuals cannot use intervening structures to disguise their ownership of a company. However, in some limited circumstances the nature of the intervening entity means that no transparency concerns arise. This is the case in relation to the four types of intervening entity described as corporate beneficial owners at Regulation 1(3), i.e., companies already subject to transparency requirements by virtue of being listed on a recognised stock exchange, trading companies owned by the States of Guernsey, the States of Alderney and legal persons whose beneficial ownership details are already on the Register of Beneficial Ownership.

³ This situation is included as an illustration only and is considered unlikely to occur in practice for the reasons set out above. Although the resident agent would not have any legal basis for challenging the activities of the trustee, see previous footnote about the actions to be taken by the authorities.

Regulation 1(3) therefore modifies the definition of beneficial owner at Regulation 1(1)(a) by specifying that these entities are to be treated as natural persons. The effect of this is that, where there is a corporate beneficial owner within the ownership structure, the ownership chain is treated as stopping with the corporate beneficial owner in the same way as it would stop with a natural person. Therefore, for registration purposes there is no need to take further steps to identify the beneficial owner of the corporate beneficial owner itself (as transparency issues do not arise for the reasons given above).

Where there is more than one Alderney company within an ownership chain, only the first company down should be treated as the beneficial owner for registration purposes, to avoid the duplication of information that would arise if it was necessary to give the details of the underlying natural person for each company in the chain.

These situations are illustrated in the examples below.

Figure 15

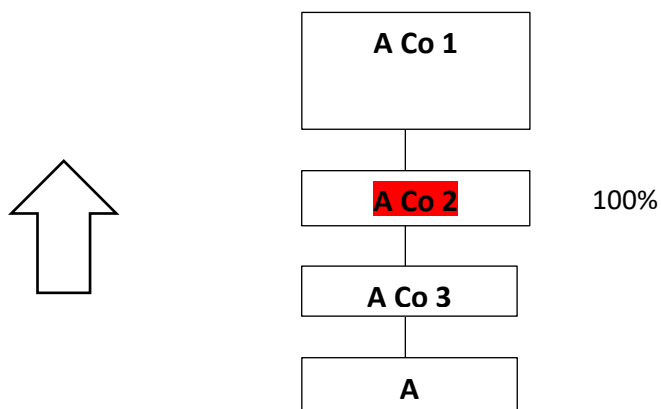

In Figure 15, A Co 1 is an Alderney company in which all the shares are held by A Co 2, another Alderney company. All the voting rights in A Co 2 are held by A Co 3, another Alderney company. All the shares in A Co 3 are held by A. A Co 2 is the beneficial owner of A Co 1 in relation to the provision of registration information on A Co 1. This is because A Co 2's beneficial ownership details are already on the Register of Beneficial Ownership, where the beneficial owner of A Co 2 will be identified as A Co 3. A Co 3's beneficial ownership details are also already on the Register of Beneficial Ownership, where the beneficial owner of A Co 3 will be identified as A. Therefore, the information necessary to track back from A Co 2 in order to identify A as the ultimate beneficial owner of A Co 1 will already be on the Register.

Figure 16

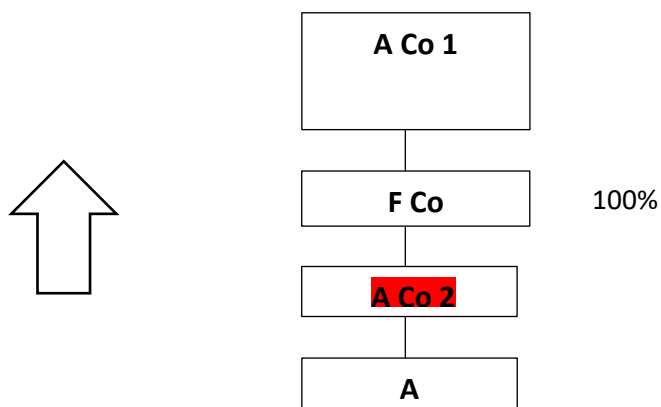

In Figure 16, A Co 1 is an Alderney company in which all of the voting rights are held by F Co, a foreign company. All of the shares in F Co are held by A Co 2, another Alderney company. All of the voting rights in A Co 2 are held by A. A Co 2 is the beneficial owner of A Co 1 in relation to the provision of registration information on A Co 1. This is because A Co 2's beneficial ownership details are already on the Register of Beneficial Ownership, where the beneficial owner of A Co 2 will be identified as A. Therefore, the information necessary to track back from A Co 2 in order to identify A as the ultimate beneficial owner of A Co 1 will already be on the Register.

FAQ 7: How do nominee arrangements fit into the registration framework?

Regulation 9 provides that, where a person holds shares for another person as a nominee, that other person is to be treated as holding the shares, not the nominee. Therefore, for the purposes of registering the beneficial ownership of the legal person in question under the Regulations, it is not necessary to provide details of the nominee. Instances of this are given at Figures 2, 4 and 9.

However, in addition to the need to identify beneficial owners, the FATF standards require nominee relationships to be identified and details provided of nominees and nominators. Therefore, this will shortly be provided for in an Ordinance made under the Law which will contain obligations about obtaining and providing information about parties to nominee relationships. To avoid duplication, this Ordinance will not require particulars relating to nominators to be provided where the nominator is also the beneficial owner or particulars relating to nominees where the nominee is also the resident agent.

Control through other means – Tier 2

FAQ 8: When does a resident agent have to look at ultimate control through other means i.e., Tier 2?

The starting point is always whether any person within Tier 1 exists or can be identified. If that is the case, that person (or persons) must be treated as the beneficial owner.

Tier 2 must be looked at in two situations. The first is where no person within Tier 1 exists or can be identified.

The second is where a person within Tier 1 has been identified but there is reason to believe that another natural person is also ultimately exercising control over the legal person by other means. In other words, although there is an identified person with a controlling ownership interest as set out in the FAQs and examples above, there is reason to believe that this controlling ownership interest does not reflect the full extent of actual control of the company. In that situation, both the person with the controlling ownership interest and the person believed to be ultimately exercising control over the company (i.e., persons within both Tier 1 and Tier 2) are the beneficial owners. Whether or not this situation arises will depend on the specific facts of every case. By way of illustration, it might arise where the person with the controlling ownership interest is dominated by another because of a familial or employment relationship, or where another person holds certain powers in relation to the company which are being or are likely to be used in practice to affect decisions taken by the person with the controlling ownership interest. See the examples at Figure 18 and Figure 19 below.

FAQ 9: What is meant by ultimate control through other means?

It is not possible to give an exhaustive definition of this because it will depend on the particular circumstances of each specific company. However, an individual is likely to have ultimate control over a company in one of two ways.

The first is where an individual has absolute decision or veto rights over the running of the business of the company. These rights may arise in a variety of ways, for example, under the official documents of the company, by being attached to shares or securities in the company held by the individual, or by virtue of a shareholder agreement or other arrangement.

Sometimes these rights are held solely to protect minority interests or are held on a temporary basis only. Each situation has to be considered on a case-by-case basis, but as a general rule the more restricted the rights or the shorter the period for which they are held, the less likely they are to give the holder ultimate control over the company. The following are examples of the kind of situations where an individual is likely to be a person with ultimate control over a company:

- having absolute decision or veto rights over the adoption or amendment of the company's business plan.
- having absolute decision or veto rights over changes to the nature of the company's business.
- having absolute decision or veto rights over making any additional borrowing from lenders.
- having absolute decision or veto rights over the appointment or removal of the CEO.
- having absolute decision or veto rights over the establishment or amendment of any profit-sharing, bonus or other incentive scheme of any nature for directors or employees.
- having absolute decision or veto rights over granting options under a share option or other share-based incentive scheme.

The second way in which an individual is likely to have ultimate control over a company is where, in practice, that individual controls the decisions that affect the activities of the company. Examples include:

- where the individual's relationship with the company or with particular individuals connected with it means that the individual regularly directs or influences the decisions of board members or the way in which shareholders vote (for example, where a father has founded a company in which he is no longer officially involved but whose directors or shareholders include family members who invariably defer to his views about decisions relating to the company).
- where the individual acts as a "shadow director" in respect of a majority of the board or otherwise directs or influences board decisions.
- where the individual uses ownership of certain rights or assets relevant to the running of the business of the company (e.g., factory premises) as a means of controlling the running of that business.
- where the individual owns or controls an entity that holds decision or veto rights over the company in the respects listed above, and may use those rights to control the activities of the company .

Ultimate control for the purposes of the Regulations will not ordinarily arise in the context of a standard professional or commercial relationship between the company and an individual such as a legal adviser, an accountant, a client, a lender, or a supplier. Nor will it ordinarily arise in the context of the exercise of a statutory function such as that of a regulator or a liquidator. However, relationships or functions of this kind may give an individual ultimate control over the company if the relationship or function is significantly different from the way in which such relationships or functions are normally understood, or if it is one of a number of opportunities the relevant individual has to influence or direct the company. In other words, what is relevant here is the substance of the relationship, not its formal description. An example where the substance of an individual's relationship would lead to the individual being treated as a beneficial owner irrespective of the individual's official status is where a company routinely deferred to its legal advisor on matters relating to the running of its business above and beyond the provision of legal advice.

Some examples are given below.

Figure 17

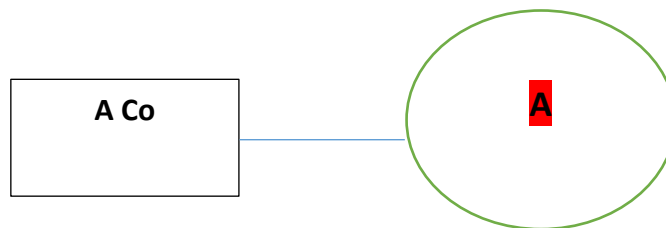

In Figure 17, A Co is an Alderney company which comprises an engineering business. Nobody comes within Tier 1 (control through ownership) and the resident agent must therefore look to see if anybody comes within Tier 2. A is the founder of the business and the official documents of A Co give him various rights over the business including the right to veto any business plan. A is therefore a beneficial owner of A Co.

Figure 18

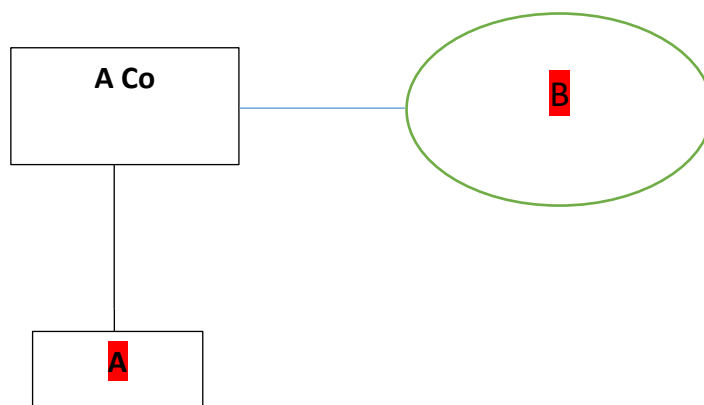

In Figure 18, A Co is an Alderney company in which A holds 100% of the voting rights. Although A works as a gardener with no other source of income, A Co has considerable assets. A's employer, B, is a very well-known international businessman who is famous for his desire for privacy, about the location of his assets. The resident agent of A Co therefore has reason to believe that, although A controls A Co through ownership, B is also ultimately controlling A Co through other means (i.e. his relationship with A), and both A and B must be treated as beneficial owners of A Co.

Figure 19

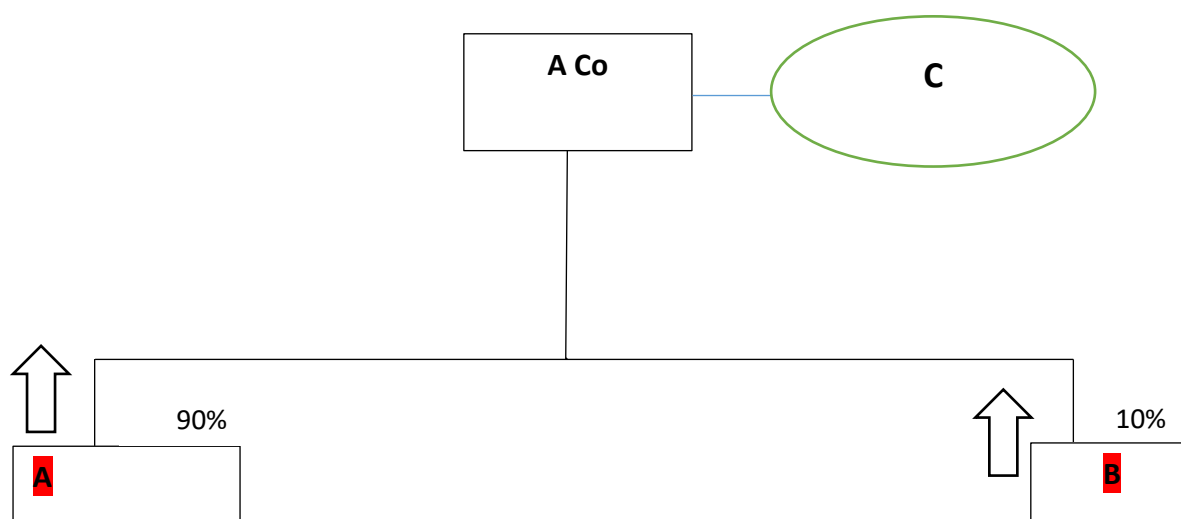

In Figure 19, A Co is an Alderney company in which A holds 90% of the shares. This means A controls A Co through ownership, so A is therefore a beneficial owner of A Co. A is the son of B. Although B's shareholding is less than 25% so B does not have control through ownership, B has ultimate control through other means as A invariably does what B wants in respect of all matters relating to the running of A Co. B is therefore also a beneficial owner of A Co. C is A Co's accountant. In addition to preparing A Co's accounts C sometimes provides A Co with advice about tax planning but this does not go beyond the standard relationship between client and accountant. Therefore, C is not a beneficial owner of A Co.

Figure 20

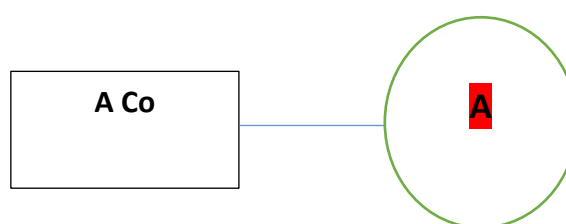

In Figure 20, A Co is an Alderney company in which nobody comes within Tier 1 (control through ownership) and the resident agent must therefore look to see if anybody comes within Tier 2. All A Co's officials are family members of the deceased person who set up the company, and none of them has any experience of the purposes for which A Co was established. As a result, in practice they always seek and follow the advice of A, who is A Co's lawyer, on any matters relating to A Co. This includes staff appointments and other things

that go beyond the kind of things normally dealt with by a legal adviser. The effect of this is that A is ultimately controlling A Co and so is the beneficial owner of A Co.

Figure 21

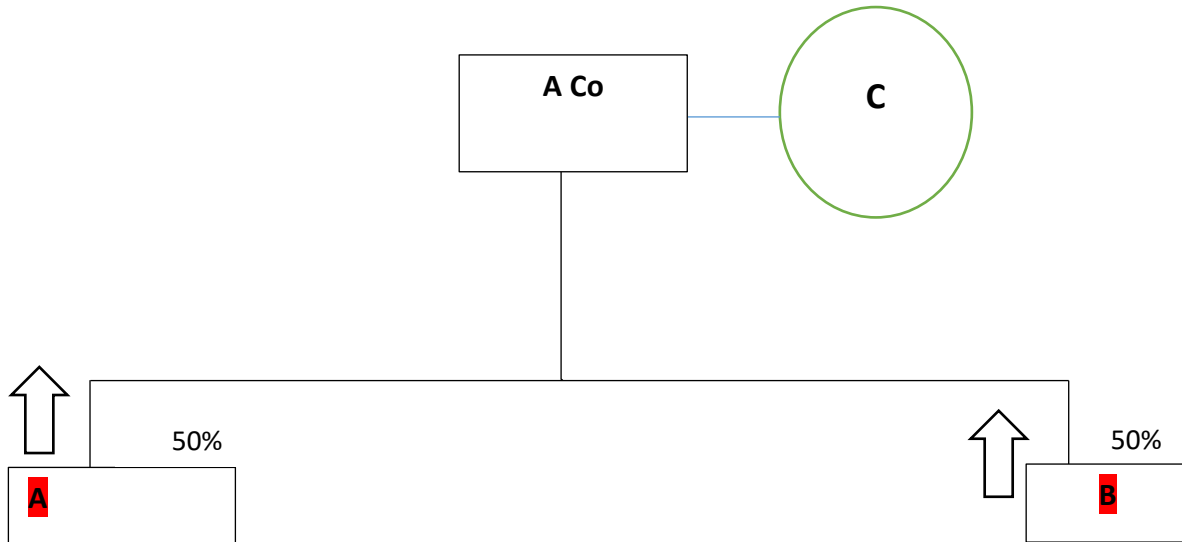

In Figure 21, A Co is an Alderney company in which A and B each hold 50% of the shares. This means A and B each control A Co through ownership, so both are beneficial owners of A Co. A Co goes into liquidation and C is appointed as the liquidator. C's handling of A Co's assets and relationships with its officials are consistent with what would normally be expected of a liquidator. C is not therefore a beneficial owner of A Co.

Control by official position – Tier 3

FAQ 10: Who is a senior managing official for the purposes of Regulation 1(c)?

As a general rule this will be a director who exercises strategic decision-making powers in respect of the company such as a director. This would not normally include a person who does not have executive functions such as a non-executive director.

In situations where there is more than one director of a company with strategic decision-making powers and none is senior to the others, all should be treated as senior managing officials.

Section 7(5) of the Law provides that, if a resident agent has ascertained that there are no beneficial owners in relation to a relevant legal person, he must record that fact in the record of beneficial owners.

This provision must be read together with the clarification in Regulation 1(1) of the Regulations which, provides that, for the avoidance of doubt, references in the Law to circumstances where a resident agent has ascertained that there are "no beneficial owners in relation to a relevant legal person" are to circumstances where no beneficial owners in relation to a relevant legal person can be identified by the resident agent of that relevant legal person.

Section 7(5) of the Law does not detract in any way from the statutory obligation to apply the 3-tiered approach to the definition of beneficial owner in the Regulations as described in this guidance. This is a failsafe provision only as it is almost inconceivable for there to be any situation where a senior managing official cannot be identified.

The registration system of the Registrar of Beneficial Ownership does not permit a resident agent to specify that a legal person has no beneficial owner(s); one or more beneficial owners must always be specified. Any resident agent wishing to rely on section 7(5) at the time of the establishment of a legal person must contact the Registrar directly to explain the reason for this. If a resident agent wishes to rely on section 7(5) for a legal person that has already been established, this could only arise if the resident agent believes that all persons previously identified as beneficial owners are no longer beneficial owners and that the resident agent is unable to identify an alternative beneficial owner under Tier 1, Tier 2 or Tier 3. This would require the details of all the existing beneficial owners to be removed from the resident agent's record of beneficial ownership, which is a change to the particulars in the record of beneficial ownership (as defined in section 7 of the Law). Such change would need to be made within 7 days under section 8(6) of the Law and then reported to the Registrar within 14 days under section 9(2). Such reporting would need to be made to the Registrar separately to use of the registration system.